

POSSIBLE MARKING CONFIGURATIONS SCALE 5:1

- 1 MATERIAL: HEADER- POLYESTER UL94V-0 (BLACK)
POST- COPPER ALLOY.
- 2 SOLDER SIDE OF P.C. BOARD SHOWN.
- 3 PARTS COMPLY WITH AMP SOLDERABILITY SPEC 109-11-2.
- 4 ONE HOLE MAY BE UNDERSIZED (.032-.035 DIA) FOR ASSEMBLY RETENTION DURING WAVE SOLDERING.
- 5 LATCH DETENT FEATURE OCCURS 2 PLACES ON EACH END (MAXIMUM OF FOUR PER PART). FOR 2 THRU 5 CIRCUIT HEADERS, LATCH FEATURE OCCURS BETWEEN EACH CIRCUIT.
- 6 COORDINATE DIMENSION APPLIES FROM CENTER OF ACTUAL FEATURE.
- 7 POST: 100% MATTE TIN PLATED.
- 8 POST MUST WITHSTAND 3.0 (13.34 NEWTONS) LBS MIN FORCE WITHOUT DISLODGING, EITHER DIRECTION.
- 9 UL AND CSA LOGO WILL APPEAR IN THIS AREA. AMP LOGO MAY APPEAR IN THIS AREA OR ON BOTTOM OF PART.
- 10 TWO SIDES OF TAPER, AS SHOWN, MUST BE PLATED. TYPICAL, BOTH ENDS.
- 11 TWO SIDES OF TAPER, AS SHOWN, AND TIP MAY BE UNPLATED. TYPICAL, BOTH ENDS.
- 12 POST: MATTE TIN-LEAD (93/7) PLATED.

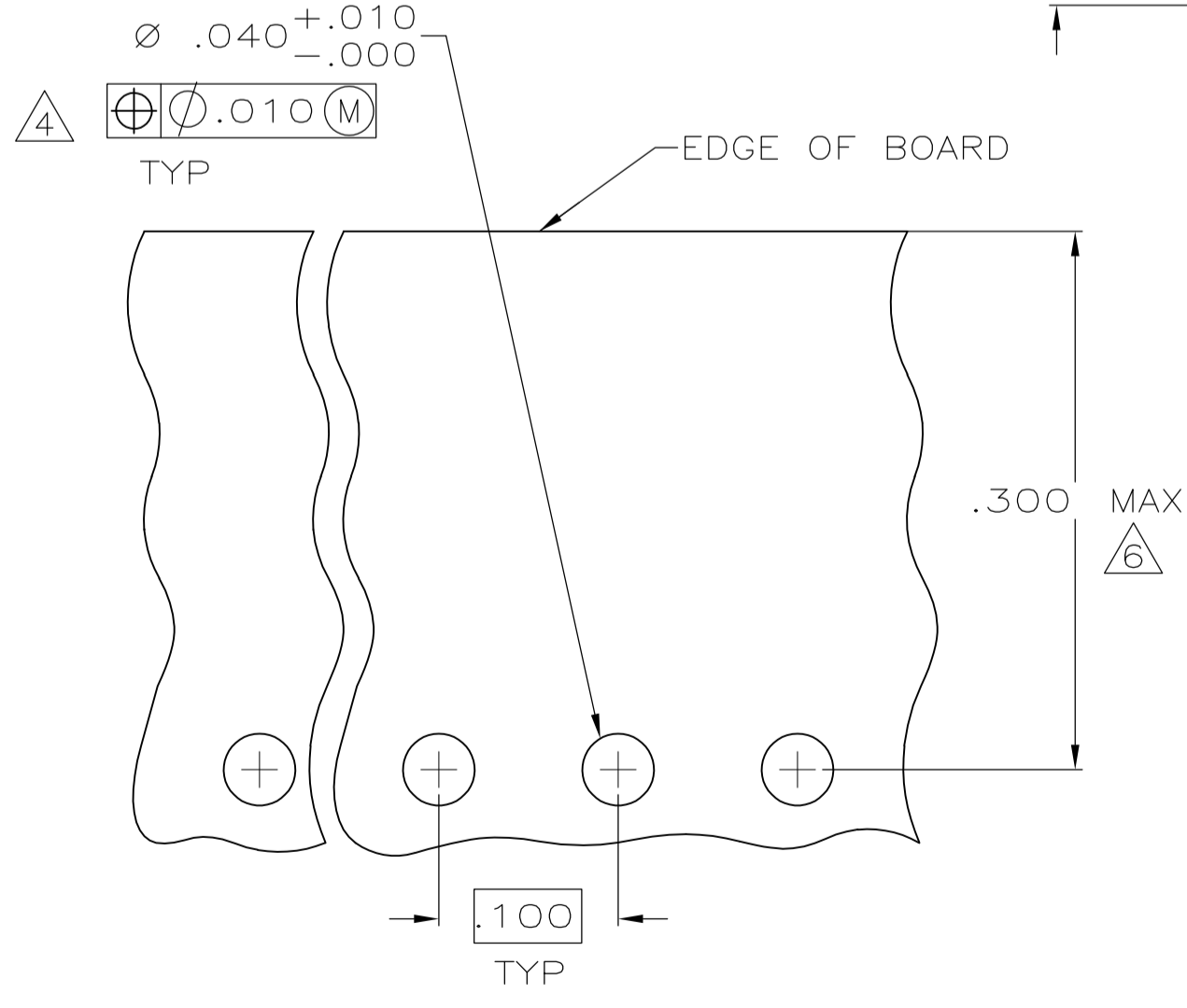
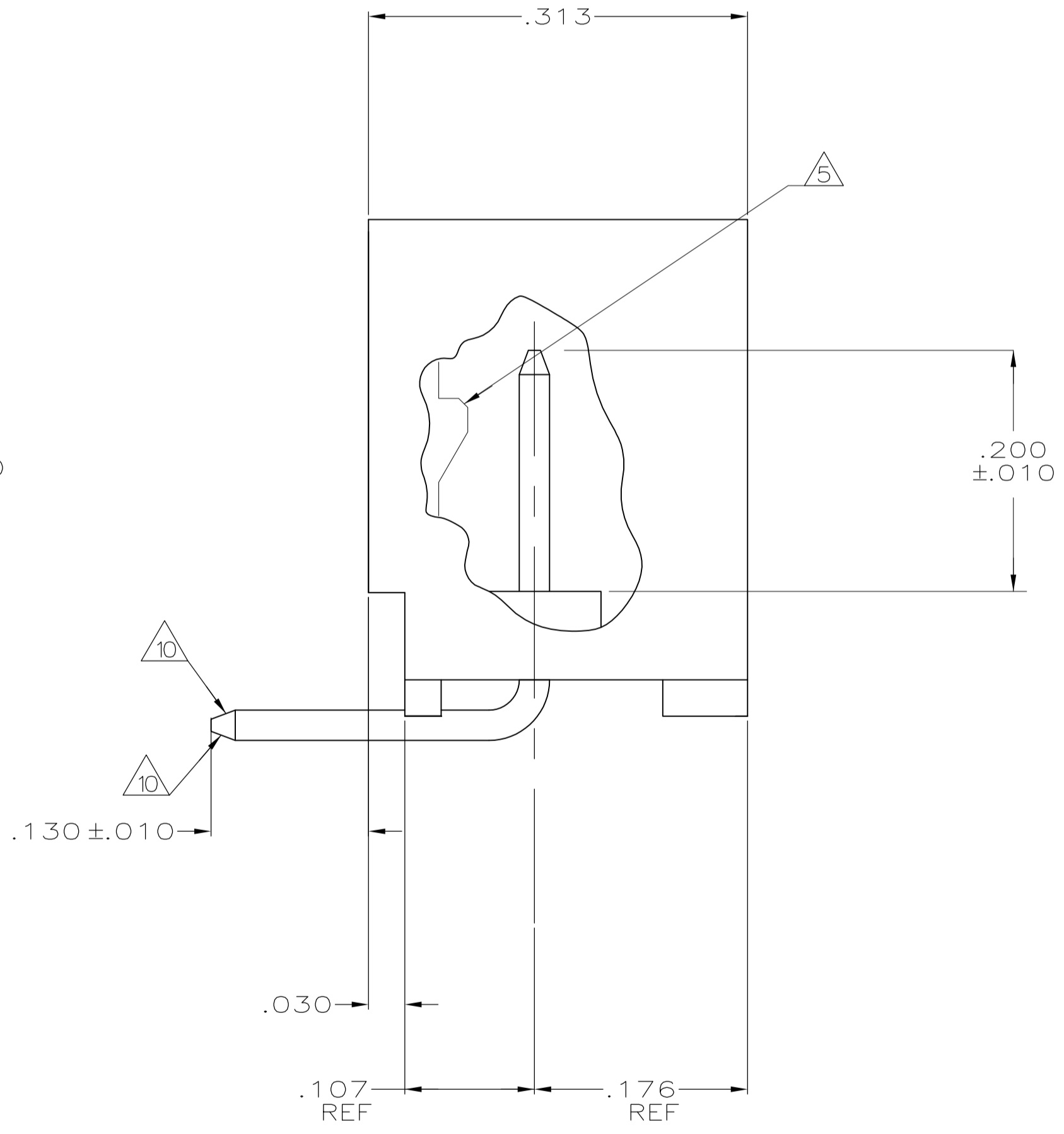
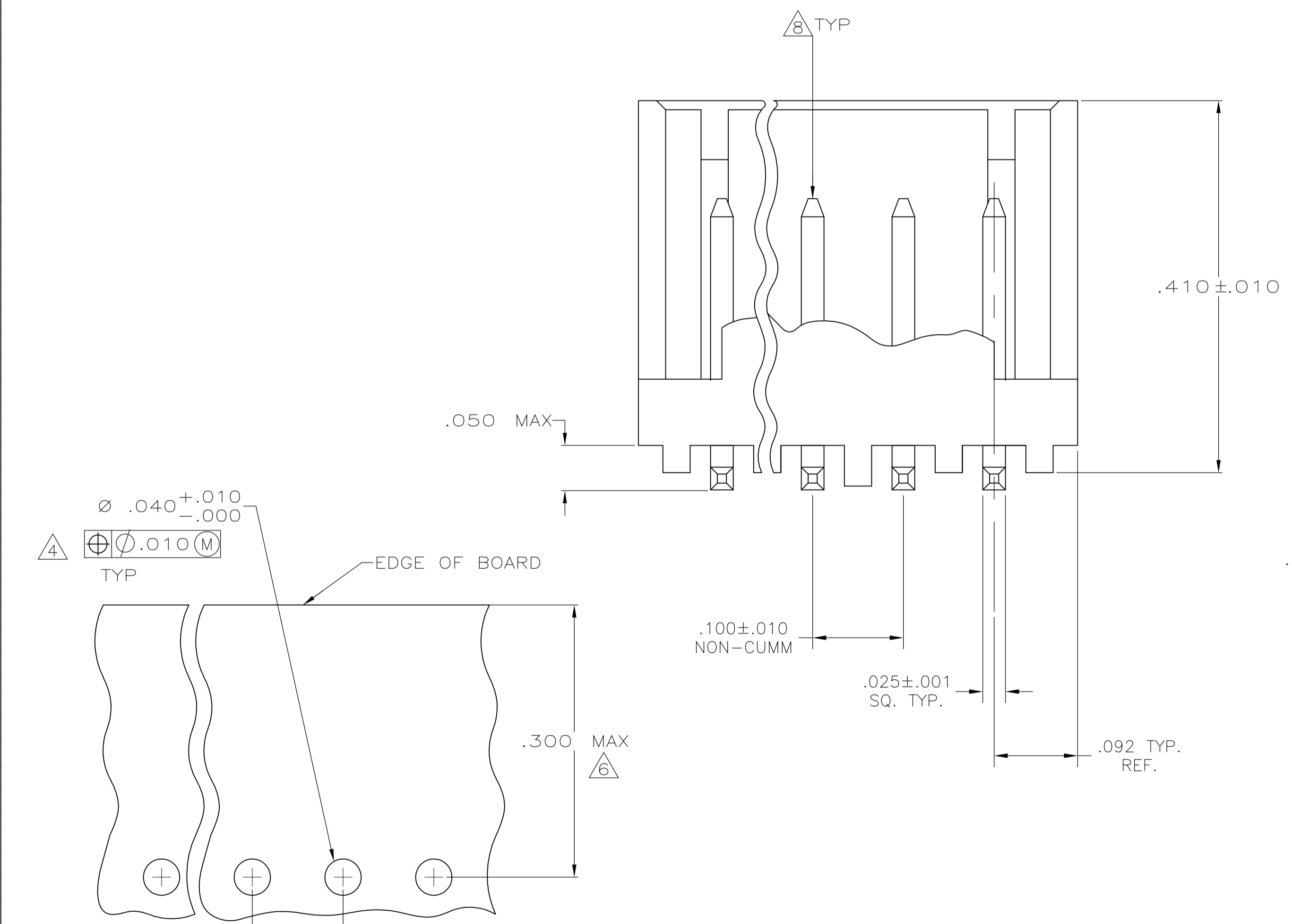

.035	0.89	.176	4.47	-	-
.032	0.81	.130	3.3	-	-
.030	0.76	.107	2.72	-	-
.025	0.64	.100	2.54	-	-
.010	0.25	.092	2.34	.410	10.41
.005	0.13	.063	1.6	.313	7.95
.001	0.03	.050	1.27	.300	7.62
.000	0	.040	1.02	.200	5.08
IN	MM	IN	MM	IN	MM

CONVERSION TABLE

YES	7	1.484	37.69	14	3-644488-4
		1.384	35.15	13	3-644488-3
		1.284	32.61	12	3-644488-2
		1.184	30.07	11	3-644488-1
		1.084	27.53	10	3-644488-0
		.984	24.99	9	2-644488-9
		.884	22.45	8	2-644488-8
		.784	19.91	7	2-644488-7
		.684	17.37	6	2-644488-6
		.584	14.83	5	2-644488-5
		.484	12.29	4	2-644488-4
		.384	9.75	3	2-644488-3
		.284	7.21	2	2-644488-2
NO	12	1.484	37.69	14	1-644488-4
		1.384	35.15	13	1-644488-3
		1.284	32.61	12	1-644488-2
		1.184	30.07	11	1-644488-1
		1.084	27.53	10	1-644488-0
		.984	24.99	9	644488-9
		.884	22.45	8	644488-8
		.784	19.91	7	644488-7
		.684	17.37	6	644488-6
		.584	14.83	5	644488-5
		.484	12.29	4	644488-4
		.384	9.75	3	644488-3
		.284	7.21	2	644488-2
LEADFREE	FINISH	IN	MM	NO OF POSITIONS	PART NUMBER
		L		HEADER ASSEMBLY	

RECOMMENDED MOUNTING HOLE PATTERN FOR .063 THK PRINTED CIRCUIT BOARD

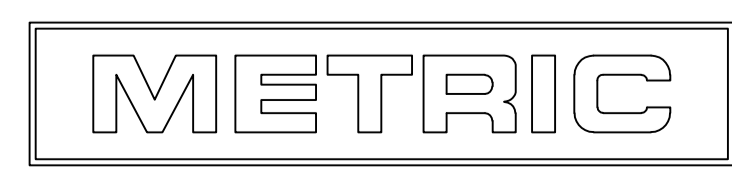

THIS DRAWING IS A CONTROLLED DOCUMENT.

DIMENSIONS: INCHES	TOLERANCES UNLESS OTHERWISE SPECIFIED:	DIN S. CARPENTER 27MAY2003	APVD D. ROSSI 28MAY2003	NAME	MTA-100 SHROUDED HEADER ASSEMBLY, FRICTION LOCK, RIGHT ANGLE POST, TIN OR TIN LEAD PLATED
	0. PLC ± -			SIZE	A1
	1. PLC ± -			CODE	00779
	2. PLC ± -			DRAWING NO	644488
	3. PLC ± .005			RESTRICTED TO	-
	4. PLC ± -			WEIGHT	
	ANGLES ± -			CUSTOMER DRAWING	

SCALE 10:1 SHEET 1 OF 1 REV H